



到 02220128

净 Q/YXLG 122  
净 , = . -

产 5

, /3/11-, , -3/ 0-31)33

会 , -3/ 0-11 , -3/ 0-32

201805

[http //www.lei-ci.com](http://www.lei-ci.com)

E-mail: [rex\\_xs@lei-ci.com](mailto:rex_xs@lei-ci.com)

Model PHS-25 pH Meter Instruction Manual



Shanghai INESA & Scientific Instrument CO.LTD

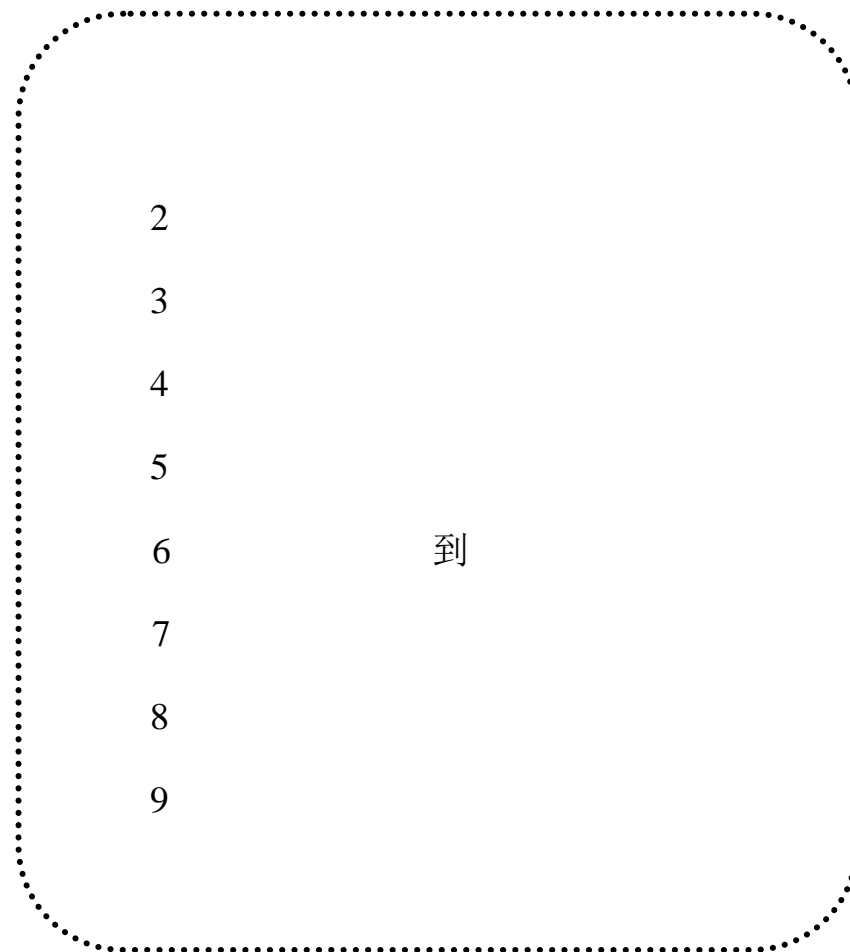
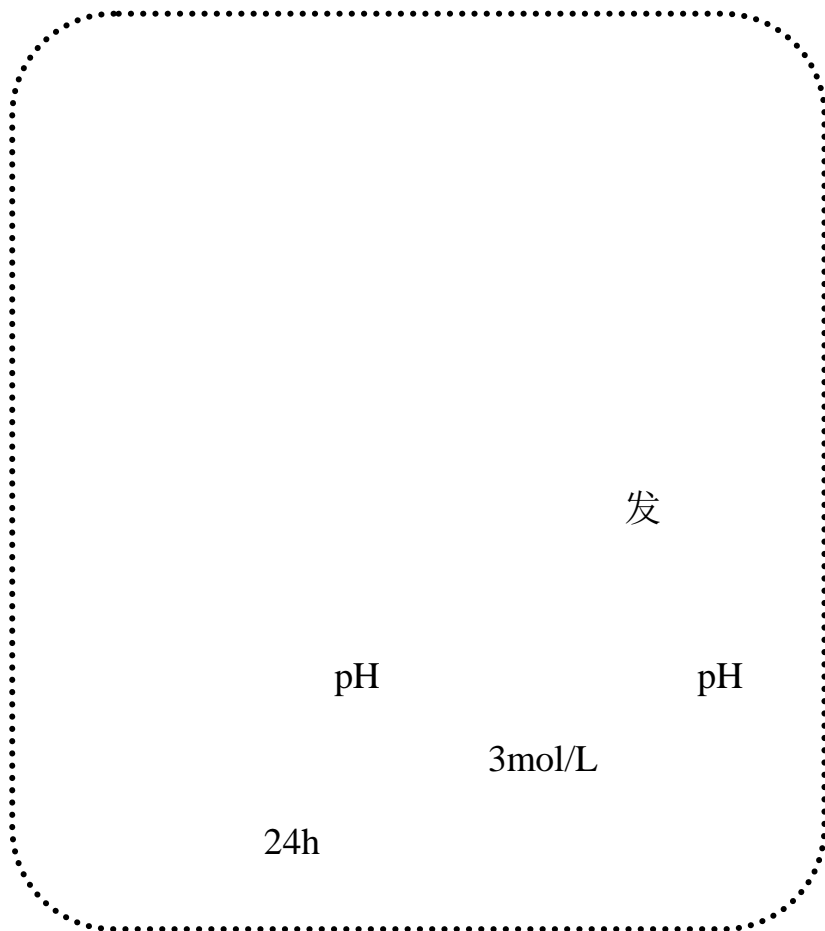

PHS 25 pH pH , 元●  
 不 ● (mV) ● pH● (mV)●  
 pH (mV) ● ORP 任且 ORP -

1( 0.1  
 2( pH (0.00~14.00) pH  
 mV 0~ 1400 mV( )

-18.88 pH●mV  
 88.8  
 pH●mV pH●mV



” ”  
 ● ●

2/  
 62/

10 Q9 ( )  
 11 E-201-C pH  
 12

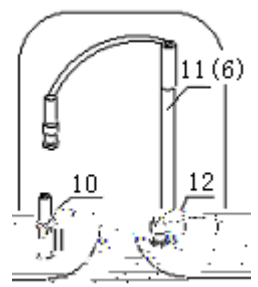

a 净 (4)  
 7 5  
 b (5)  
 c pH (11)  
 (4) 5

4 5

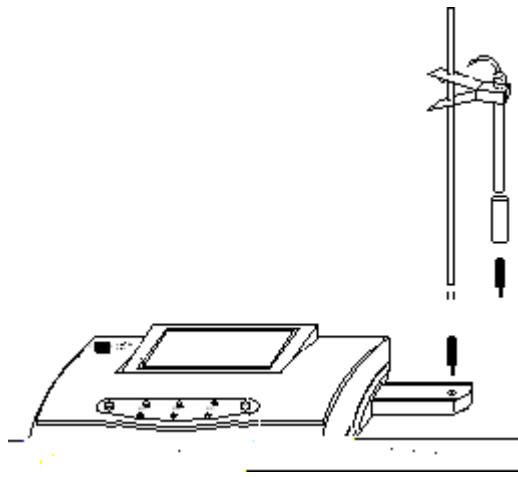

d E-201-C pH  
 (1, )  
 与  
 5

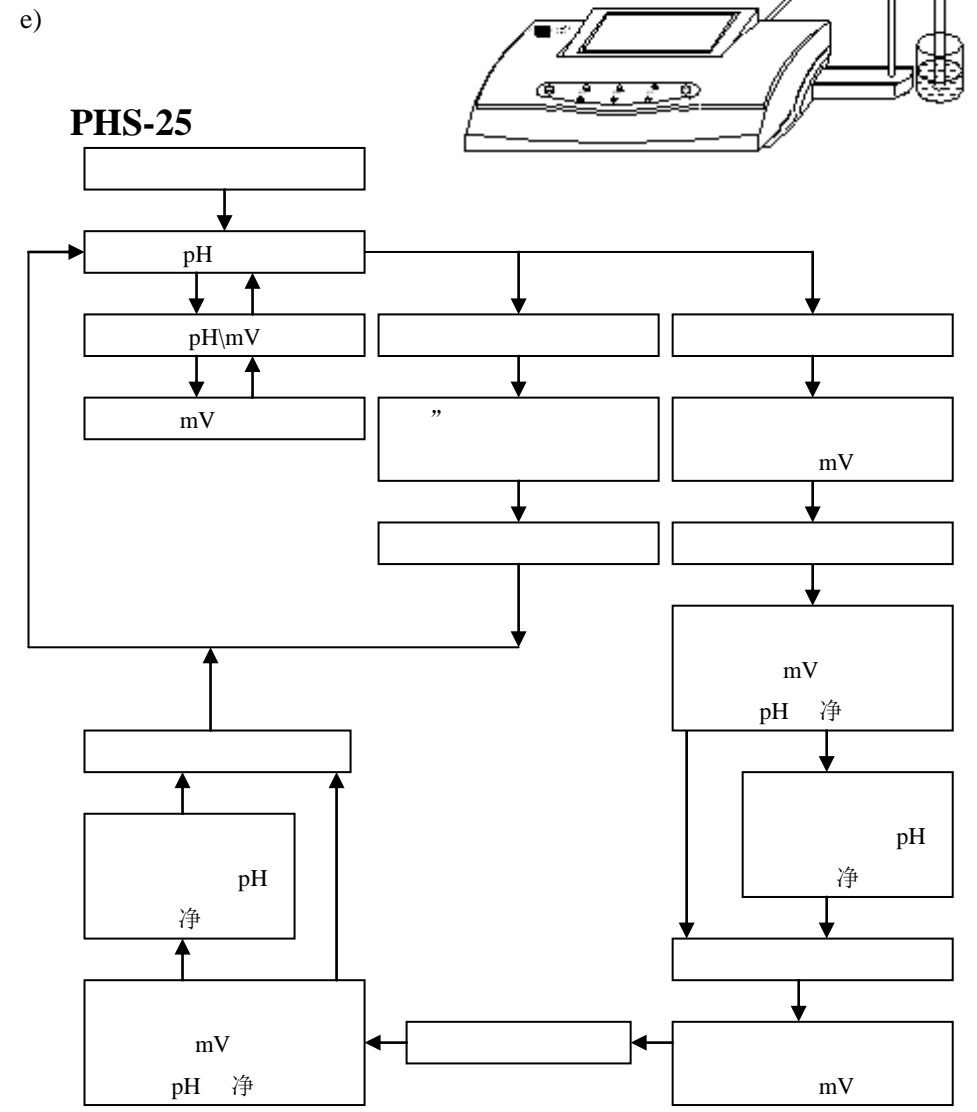
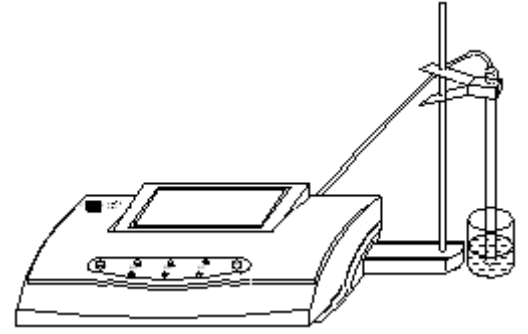

.( " .( ● 0(20 ● 3( 2 净

- a) 8 Q9 (10)5
- b) 8 (11)5
- c) pH 5
- d) ”
- e) pH 5  
pH 9.18) 净 pH=6.86pH( pH 4.005  
P  
净  
pH 5
- f) pH 4.00( pH 9.185 pH=6.86E2F6A066C0A

---

---

"	pH	5	V P
" P			
" ,	5		
" _			5
" .		2	5
" /	ORP		



